

- Giunto antivibrante flangiato - PN16
- Flanged rubber flexible joint - PN16
- Gummi-Kompensator Flanschanschlüsse - PN16
- Manchon antivibration à brides - PN16
- Фланцевая антивибрационная вставка - PN16

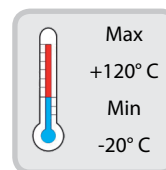

N	DENOMINAZIONE PART NAME	MATERIALE MATERIAL	TRATTAMENTO TREATMENT
1	Flangia - Flange	Acciaio al carbonio Carbon steel	Zincato Zinc plated
2	Corpo - Body	EPDM - Nylon	

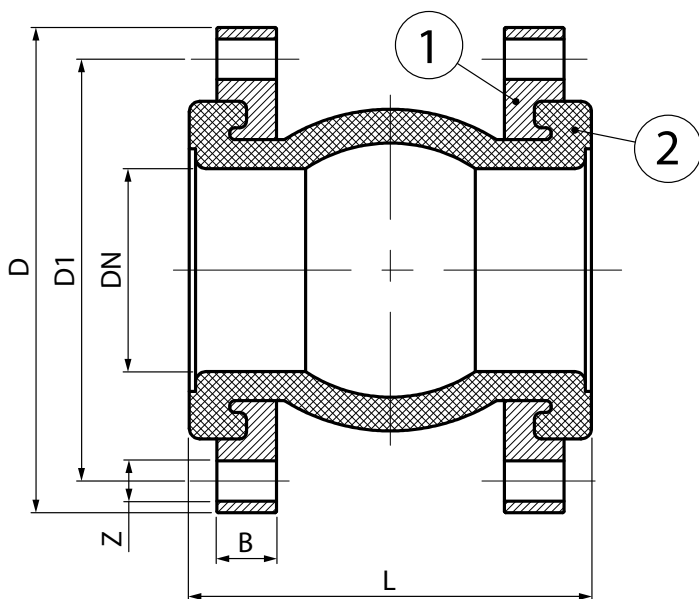

### DIMENSIONI - DIMENSIONS (mm)

DN	L	D	D1	B	Z
32	95	134	100	18	4xØ18
40	95	143	110	15	4xØ18
50	105	165	125	19	4xØ18
65	115	185	145	21	8xØ18
80	135	200	160	21	8xØ18
100	150	220	180	23	8xØ18
125	165	250	210	25	8xØ18
150	180	285	240	25	8xØ23
200	210	340	295	27	12xØ23
250	230	405	355	29	12xØ25
300	230	460	410	29	12xØ25